

## A100 Series Quarter Turn Electric Actuators

A100 series electric actuators are manufactured for on/off or proportional control of quarter turn butterfly, ball and plug valves and dampers.

The electric actuators are manufactured according to industrial standards with high quality for iron and steel, chemical, marine, mining, paper, cement plants, as well as general industrial applications and water treatment plants, HVAC sector.

The electric actuators have the complete compliance with ISO5211 flange standard which allow the direct mounting to the valves with the same standard.

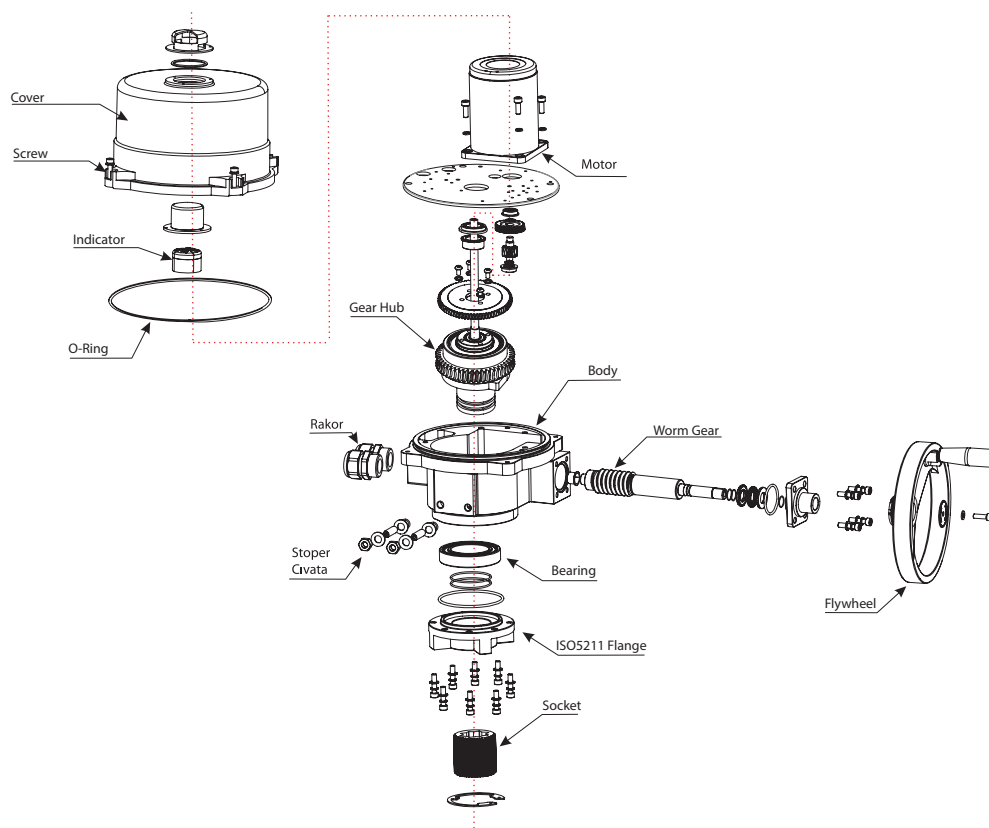

### Technical Specifications

Torque Output	Produced in different models covering a wide torque range from 30Nm to 20000Nm.
Enclosure	Injection molded aluminium with epoxy coating suitable for harsh environmental conditions
Ingress Protection	Standard IP67. IP68 housing option is available upon request
Sealing Elements	Double o-ring system is utilized to ensure a perfectly tight seal
Manual Override	Wrench for PRO30 and PRO50. Clutchless design handwheel for PRO80 and above models.
Position Locking	Self locking gearing system to prevent valves from being back driven.
Motor	High-efficiency motor with built in thermal protection.
Limit Switches	2 pieces for each end of actuator travel. Auxiliary switches are available upon request.
Torque Switches	Prevents structural motor overloads, interrupting the motor power when the output torque exceeds a specified amount.
Mechanical Stoppers	Designed to prevent the actuator from over traveling in case limit switches fail to fulfill their function thus potential damages to gear train are avoided.
Visual Position Indicator	Mechanical dome type with highly visible red/green indicator
Terminal Block	Push-in type terminal strip facilitating wire termination and more secure for areas subject to vibration
Operating Temperature	On/Off Duty * Modulating Duty*
Working Angle	90° (0° ~ 100°)
Space Heater	Anti-condensation Heater 5W(110/220VAC). Higher wattage heaters for extreme cold conditions are optionally available.
Voltage Range	0-95% RH
Duty Cycle	S2:10-30min/S4:20-50%
Duty Cycle(Modulating)	S4:30-50%,300-1200 Starts/hour



## A100 Series Quarter Turn Electric Actuators Technical Information

Model Number	Item Code	Power Supply	Torque (Nm)	Torque Switch	Cycle Time (Sec.)	Motor Power (W)	Duty Cycle		Current Draw (A)		
							On/Off	Modulating	Start	Run	LRA
PRO 030	A100FEP2003	24VDC	30	N/A	11	10W	25%	50%	1,88	0,75	1,45
	A100FEP3003	220VAC (50/60Hz)					25%	50%	0,13	0,05	0,10
PRO 050	A100FEP2005	24VDC	50	N/A	10	6W	25%	50%	2,25	0,9	1,80
	A100FEP3005	220VAC (50/60Hz)			15/13	10W	25%	50%	0,53	0,21	0,50
PRO 080	A100FEP2008	24VDC	80	N/A	15	10W	25%	50%	2,25	0,9	1,80
	A100FEP3008	220VAC (50/60Hz)			22/18		25%	50%	0,50	0,21	0,50
PRO 100	A100FEP2010	24VDC	100	√	14	40W	25%	50%	8,00	3,2	6,00
	A100FEP3010	220VAC (50/60Hz)			19/16		25%	50%	1,00	0,42	0,80
	A100FEP4010	380VAC			19/16		25%	50%	0,80	0,32	0,60
PRO 200	A100FEP2020	24VDC	200	√	28	40W	25%	50%	8,00	3,2	6,00
	A100FEP3020	220VAC (50/60Hz)			39/33		25%	50%	1,00	0,42	0,80
	A100FEP4020	380VAC			39/33		25%	50%	0,80	0,32	0,60
PRO 300	A100FEP2030	24VDC	300	√	28	60W	25%	33%	8,50	3,5	6,50
	A100FEP3030	220VAC (50/60Hz)			39/33		25%	33%	1,15	0,46	0,85
	A100FEP4030	380VAC			39/33		25%	33%	0,80	0,35	0,65
PRO 400	A100FEP2040	24VDC	400	√	21	60W	25%	50%	14,00	5,6	10,50
	A100FEP3040	220VAC (50/60Hz)			29/24		25%	50%	2,20	0,9	1,80
	A100FEP4040	380VAC			29/24		25%	50%	1,50	0,62	1,20
PRO 600	A100FEP2060	24VDC	600	√	28	90W	25%	50%	14,00	5,6	10,50
	A100FEP3060	220VAC (50/60Hz)			39/33		25%	50%	2,20	0,9	1,80
	A100FEP4060	380VAC			39/33		25%	50%	1,50	0,62	1,20
PRO 800	A100FEP2080	24VDC	800	√	34	90W	25%	50%	14,00	5,6	10,50
	A100FEP3080	220VAC (50/60Hz)			47/39		25%	50%	2,20	0,9	1,80
	A100FEP4080	380VAC			47/39		25%	50%	1,50	0,62	1,20
PRO 1000	A100FEP2100	24VDC	1000	√	34	120W	25%	50%	20,00	8,4	16,00
	A100FEP3100	220VAC (50/60Hz)			47/39		25%	50%	2,50	1,1	2,00
	A100FEP4100	380VAC			47/39		25%	50%	2,00	0,8	1,50
PRO 1300	A100FEP3130	220VAC (50/60Hz)	1300	√	47/39	120W	25%	33%	3,20	1,3	2,50
	A100FEP4130	380VAC			47/39		25%	33%	2,30	0,92	1,75
PRO 1700	A100FEP3170	220VAC (50/60Hz)	1700	√	34/28	120W	25%	33%	5,50	2,2	4,00
	A100FEP4170	380VAC			34/28		25%	33%	2,50	1,1	2,00
PRO 2000	A100FEP3200	220VAC (50/60Hz)	2000	√	34/28	120W	25%	33%	6,20	2,5	4,50
	A100FEP4200	380VAC			34/28		25%	33%	3,20	1,3	2,50
PRO 2300	A100FEP3230	220VAC (50/60Hz)	2300	√	47/39	120W	25%	33%	5,50	2,2	4,50
	A100FEP4230	380VAC			47/39		25%	33%	2,50	1,1	2,00
PRO 3500	A100FEP3350	220VAC (50/60Hz)	3500	√	76/63	200W	25%	33%	5,50	2,2	4,50
	A100FEP4350	380VAC			76/63		25%	33%	2,50	1,1	2,00
PRO 5000	A100FEP3500	220VAC (50/60Hz)	5000	√	105/88	200W	25%	33%	5,50	2,2	4,50
	A100FEP4500	380VAC			105/88		25%	33%	2,50	1,1	2,00
PRO 8000	A100FEP3800	220VAC (50/60Hz)	8000	√	143/119	200W	25%	33%	5,50	2,2	4,50
	A100FEP4800	380VAC			143/119		25%	33%	2,50	1,1	2,00
PRO 13000	A100FEP41300	380VAC	13000	√	109/91	400W	25%	33%	5,00	2,00	3,60
PRO 16000	A100FEP41600	380VAC	16000	√	129/108	400W	25%	33%	5,00	2,00	3,60
PRO 20000	A100FEP42000	380VAC	20000	√	155/129	400W	25%	33%	5,00	2,00	3,60

## A100 Quarter Turn Electric Actuators

### PRO 030 Model Electric Actuators

Model	PRO 030
Series	A100 FEP
Supply	24V AC/DC, 110V AC, 220V AC
Torque	30 Nm
F1/F2/F3	F03/F04/F05
Spindle Shaft	11x11
Weight (Kg)	1.0 Kg

#### Optional Accessories

IP68 Protection Class
Potentiometer (1 K Ohm)
RPC - 4-20 mA Remote Proportional Control Unit
4-20 mA Position Transmitter

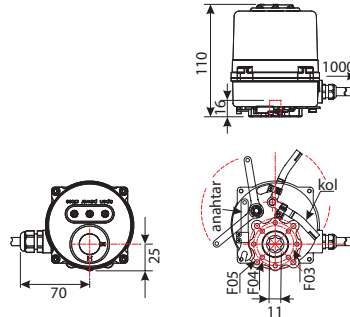

### PRO 050 Model Electric Actuators

Model	PRO 050
Series	A100 FEP
Supply	24V AC/DC, 110V AC, 220V AC
Torque	50 Nm
F1/F2/F3	F05/F07
Spindle Shaft	14x14
Weight (Kg)	3.2 Kg

#### Optional Accessories

IP68 Protection Class
Potentiometer (1 K Ohm)
RPC - 4-20 mA Remote Proportional Control Unit
Local Control Unit
4-20 mA Position Transmitter
Fail-Safe Battery Back-Up

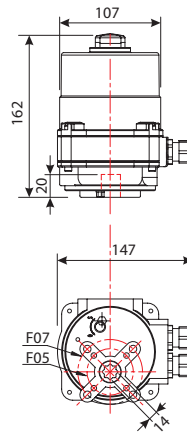

### PRO 080 Model Electric Actuators

Model	PRO 080
Series	A100 FEP
Supply	24V AC/DC, 110V AC, 220V AC
Torque	80 Nm
F1/F2/F3	F05/F07
Spindle Shaft	17x17
Weight (Kg)	3.8 Kg

#### Optional Accessories

IP68 Protection Class
Potentiometer (1 K Ohm)
RPC - 4-20 mA Remote Proportional Control Unit
Local Control Unit
4-20 mA Position Transmitter
Fail-Safe Battery Back-Up

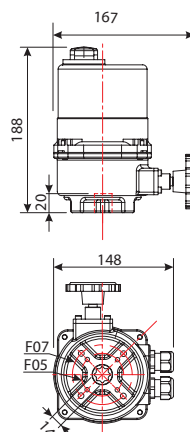



### PRO 100 - 2300 Model Electric Actuators

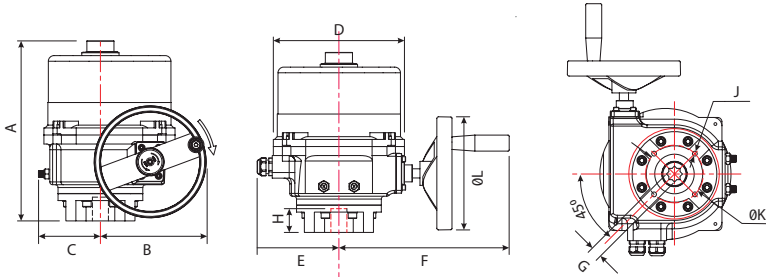

### PRO 3500 - 8000 Model Electric Actuators

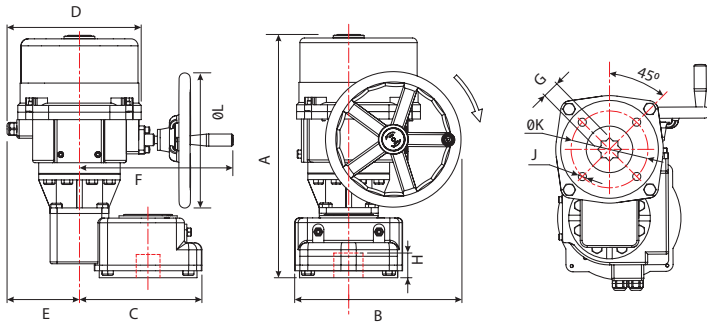

### PRO 13000 - 20000 Model Electric Actuators

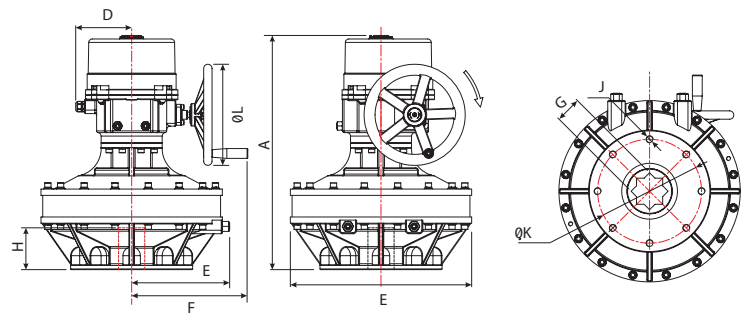

#### Dimensions(mm)

Model	Item Code	Torque (Nm)	A	B	C	D	E	F	G	H	ISO5211 ØK	J	ISO5211 Top Flange	Conduit Entri	Unit Weight (Kg)
PRO 100	A100FEPX010	100	268	77	123	216	121	240	14X14	35	70	4-M8	F07 + F10	2 X PG16	11,00
									17X17						
PRO 200	A100FEPX020	200	268	77	123	216	121	240	14X14	35	70	4-M8	F07+ F10	2 X PG16	11,00
									17X17						
PRO 300	A100FEPX030	300	268	77	123	216	121	240	14X14	35	70	4-M8	F07 + F10	2 X PG16	11,00
									17X17						
PRO 400	A100FEPX040	400	327	103	187	266	150	297	22x22	55	102	4-M10	F10 + F12	2 X PG16	22,00
									22x22						
PRO 600	A100FEPX060	600	327	103	187	266	150	297	27x27	55	125	4-M12	F10 + F12	2 X PG16	22,00
									27x27						
PRO 800	A100FEPX080	800	327	103	187	266	150	297	27x27	55	125	4-M12	F14	2 X PG16	22,00
PRO 1000	A100FEPX100	1000	327	103	187	266	150	297	27x27	55	125	4-M12	F14	2 X PG16	22,00
PRO 1300	A100FEPX130	1300	327	103	187	266	150	297	27x27	55	125	4-M12	F14	2 X PG16	22,00
PRO 1700	A100FEPX170	1700	380	127	242	293	161	333	27x27	65	125	4-M16	F14	2 X PG16	36,00
											140				
PRO 2000	A100FEPX200	2000	380	127	242	293	161	333	27x27	65	125	4-M16	F14	2 X PG16	36,00
											140				
PRO 2300	A100FEPX230	2300	380	127	242	293	161	333	36x36	65	125	4-M16	F16	2 X PG16	36,00
											140				
PRO 3500	A100FEPX350	3500	532	118	242	293	308	186	40x40	85	140	4-M16	F16	2 X PG16	76,00
											165				
PRO 5000	A100FEPX500	5000	532	118	242	293	308	186	46x46	85	165	4-M20	F16	2 X PG16	76,00
PRO 8000	A100FEPX800	8000	545	160	242	293	343	160	55x55	130	254	8-M16	F25	2 X PG16	107,00
PRO 13000	A100FEPX1300	13000	672	520	-	293	281	331	55x55	120	254	8-M16	F25 / F30	2 X PG16	218,00
									75x75						
PRO 16000	A100FEPX1600	16000	672	520	-	293	281	331	55x55	120	298	8-M20	F25 / F30	2 X PG16	218,00
									75x75						
PRO 20000	A100FEPX2000	20000	672	520	-	293	281	331	55x55	120	298	8-M20	F25 / F30	2 X PG16	218,00
									75x75						

\*X refers to power supply. X=2 for 24VDC, X=3 for 220VAC, X=4 for 380VAC actuators