

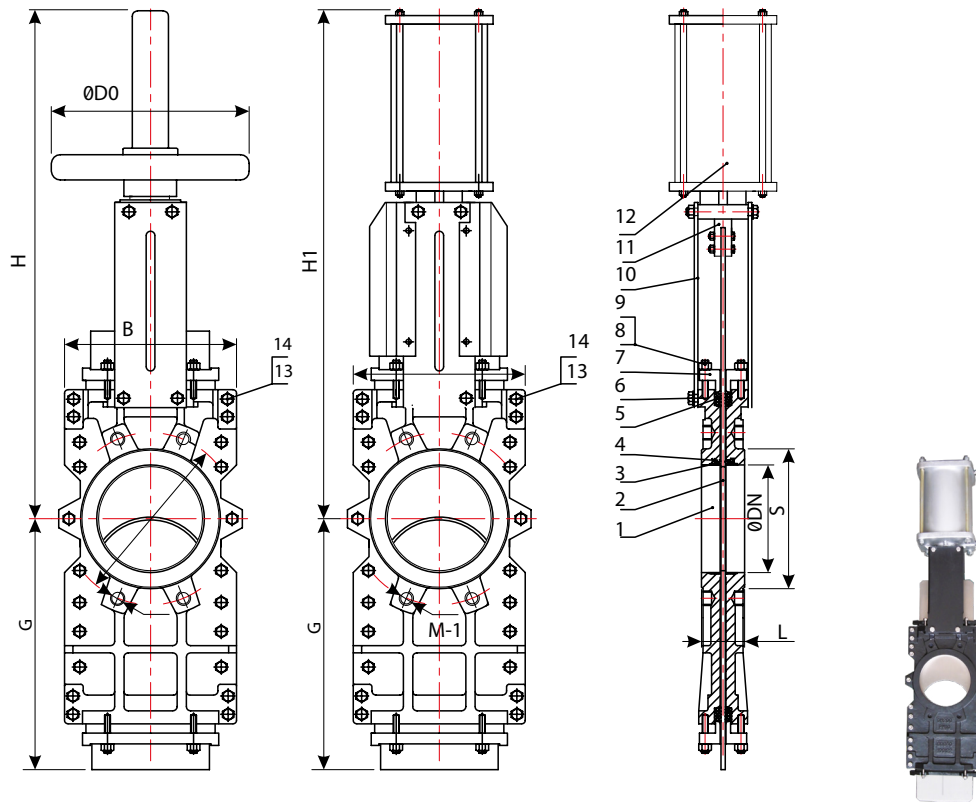

V303 Series Straight-Through Knife Gate Valves

- Available in sizes ranging from DN50 to DN600 with a split body configuration providing bi-directional bubble tight shut-off at full rated pressure.
- Ideally suited to be used particularly in pneumatic conveying of high viscosity paper pulp and media containing abrasive powders .



No	Part Name	Material
1	Body	GG25
		GGG40
		WCB
		SS304
		SS316
2	Gate	SS304
		SS316
3	Retaining Ring	304/316
4	Seat	EPDM
		Viton
		NBR
		Metal
5	Packing	PTFE+Silicone
6	Cap Screw	SS304
7	Packing Gland	GGG40
8	Set Screw	SS304
9	Gland Nut	SS304
10	Support Plate	ASTM A36
11	Stem	SS304
12	Pneumatic Cylinder	Aluminum
13	Cap Screw	SS304
14	Nut	SS304

Dimensions(mm)

Size (DN)	L	ØD	ØD0	S	G	B	H	H1	Max Operating Pressure	Supply Port (B.S.P)	Wafer Type PN10			Net Unit Weight (kg)	
											M			Manuel	Pneumatic
50	40	125	180	95	225	136	470	560	10 bar	1/4"	M16	4	-	12,0	14,0
65	40	145	180	110	265	151	525	600	10 bar	1/4"	M16	4	-	14,0	16,0
80	50	160	200	127	310	170	565	660	10 bar	1/4"	M16	4	4	16,0	18,0
100	50	180	200	148	370	190	640	740	10 bar	1/4"	M16	4	4	20,0	23,0
125	50	210	220	174	430	212	715	860	10 bar	1/4"	M16	4	4	29,0	34,0
150	60	240	250	199	495	230	830	950	10 bar	1/4"	M20	4	4	35,0	41,0
200	60	295	300	250	630	286	1030	1150	8 bar	1/4"	M20	4	4	62,0	73,0
250	70	350	350	308	770	338	1250	1320	6 bar	3/8"	M20	8	4	89,0	105,0
300	70	400	350	360	895	388	1450	1550	6 bar	3/8"	M20	8	4	110,0	128,0
350	96	460	400	416	1050	460	1640	1720	5 bar	3/8"	M20	12	4	174,0	210,0
400	100	515	500	466	1185	520	1850	1960	5 bar	3/8"	M24	12	4	266,0	310,0
450	106	565	500	518	1320	580	2075	2150	3 bar	1/2"	M24	16	4	326,0	380,0
500	110	620	600	572	1455	620	2325	2300	3 bar	1/2"	M24	16	4	372,0	450,0
600	110	725	700	664	1720	720	2690	2700	3 bar	1/2"	M27	16	4	445,0	640,0